

Data Sheet



Sensor with Ex approval

GTE Analog

Magnetostrictive Linear Position Sensors

- Offers redundancy for Enhanced Safety Applications (ESA)
- Embeddable for added protection in harsh environments
- ATEX- / IECEx- certification (optionally)

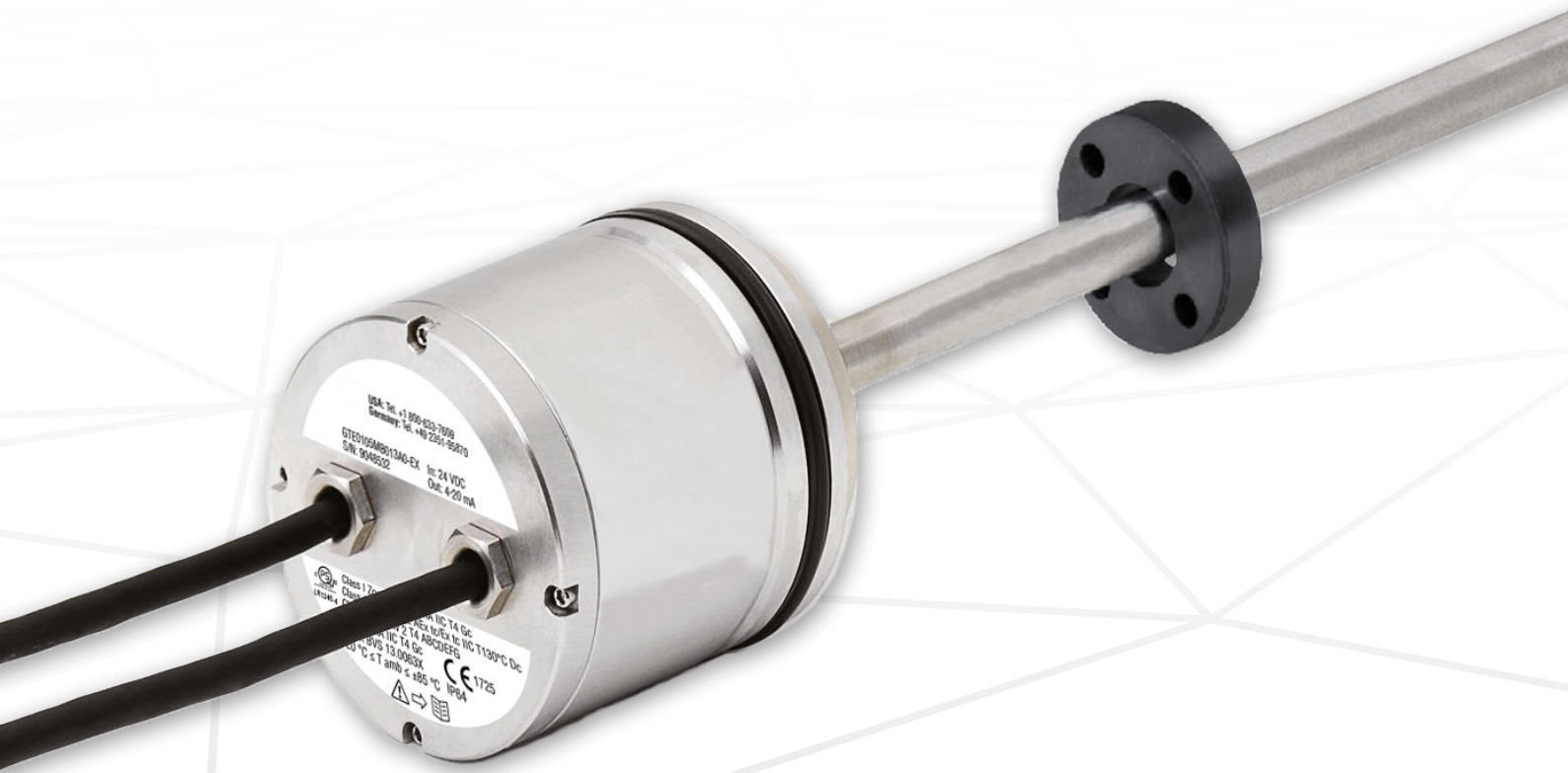

MEASURING TECHNOLOGY

The absolute, linear position sensors provided by Temposonics rely on the company's proprietary magnetostrictive technology, which can determine position with a high level of precision and robustness. Each Temposonics position sensor consists of a ferromagnetic waveguide, a position magnet, a strain pulse converter and supporting electronics. The magnet, connected to the object in motion in the application, generates a magnetic field at its location on the waveguide. A short current pulse is applied to the waveguide. This creates a momentary radial magnetic field and torsional strain on the waveguide. The momentary interaction of the magnetic fields releases a torsional strain pulse that propagates the length of the waveguide. When the ultrasonic wave reaches the end of the waveguide it is converted into an electrical signal. Since the speed of the ultrasonic wave in the waveguide is precisely known, the time required to receive the return signal can be converted into a linear position measurement with both high accuracy and repeatability.

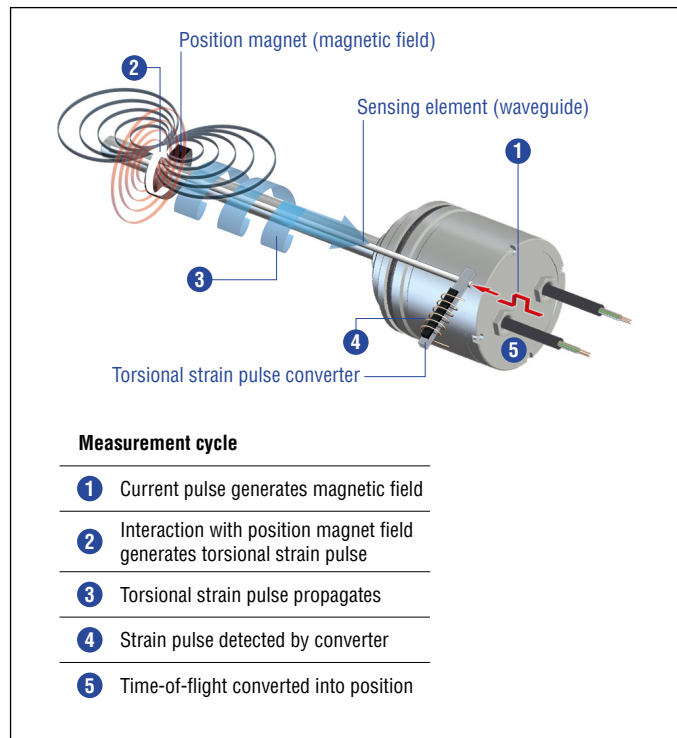

Fig. 1: Time-of-flight based magnetostrictive position sensing principle

GTE ANALOG





The Temposonics® G-Series redundant GTE sensors provide precise, linear position measurement for applications where redundancy optimizes safety relevant functions. They are extremely robust and ideal for continuous operation under harsh industrial conditions.

The embedded redundant sensors feature two independent measuring systems in one compact housing. Each system contains a separate channel with sensor element, power and evaluation electronics, output signal and cable connection. Both sensor elements are integrated in a pressure-resistant, high-quality stainless steel rod with a diameter of 10 mm (0.39 inch), which can withstand the high pressures prevailing in hydraulic cylinders. The setting of the setpoints (zero/span) is possible over the entire electronic stroke length with 50 mm (2 inches) minimum distance between the individual measuring points. The redundant sensor is easily installed in applications that measure linear motion in control valves, linear actuators, hydraulic cylinders, and machinery.



Fig. 2: Typical application: Power plants

TECHNICAL DATA

Output	
Voltage	0...10 VDC, 10...0 VDC, -10...+10 VDC, +10...-10 VDC (minimum controller load: > 5k Ω)
Current	4...20 mA, 20...4 mA, 0...20 mA, 20...0 mA (minimum/maximum load: 0/500 Ω)
Measured value	Position
Measurement parameters	
Resolution: Position	Infinite (restricted by output ripple)
Cycle time	< 1 ms (typical)
Linearity deviation	< ±0.02 % F.S. (minimum ±50 μm)
Repeatability	< ±0.001 % F.S. (minimum ±2.5 μm)
Hysteresis	< 4 μm
Operating conditions	
Operating temperature	-40...+75 °C (-40...+167 °F) 
Humidity	90 % relative humidity, no condensation
Ingress protection	IP64
Shock test	100 g (single shock) according to IEC 60068-2-27 (survivability)
Vibration test	10 g/10...2000 Hz according to IEC60068-2-6 (resonance frequencies excluded)
EMC test	Electromagnetic emission according to EN 61326-1 and EN 55011 Electromagnetic immunity according to EN 61326-1 The sensor meets the requirements of the EU directives and is marked with 
Operating pressure	350 bar static (5076 psi static), 690 bar peak (10,000 psi peak)
Agency approvals (Optional)	
Non-sparking	 Class I Zone 2 AEx/Ex nA IIC T4 Gc Class II / III Zone 22 AEx tc / Ex tc IIC T130 °C Dc Class I / II / III Div 2 T4 ABCDEFG  II 3G Ex nA IIC T4 Gc IECEX BVS 13.0063X $-20\text{ °C} \leq T_{\text{amb}} \leq +75\text{ °C}$ ($-4\text{ °F} \leq T_{\text{amb}} \leq +167\text{ °F}$)
Design / Material	
Sensor electronics housing	Stainless steel 1.4305 (AISI 303)
Sensor rod	Stainless steel 1.4306 (AISI 304L)
Stroke length	50...2540 mm (2...100 in.)
Mechanical mounting	
Mounting position	Any
Mounting instruction	Please consult the technical drawing on page 4
Electrical connection	
Connection type	Cable output
Operating voltage	+24 VDC (-15/+20 %)
Current consumption	100 mA typical per channel
Dielectric strength	700 VDC (DC ground to machine ground)
Polarity protection	Up to -30 VDC
Overvoltage protection	Up to 36 VDC

CERTIFICATIONS

Certification required	GTE-xxxxx-Bxx-1-xx-EX (+24 VDC (-15/+20 %))
IECEX / ATEX (IECEX: Global market; ATEX: Europe)	Ex nA IIC T4 Gc Zone 2 $-40\text{ °C} \leq T_a \leq +75\text{ °C}$ ($-40\text{ °F} \leq T_a \leq +167\text{ °F}$)
NEC (USA)	Class I/II/III Div 2 T4 Groups ABCDEFG Class I, Zone 2, AEx nA IIC T4 Class II/III, Zone 22, AEx tc IIC T130 °C $-20\text{ °C} \leq T_a \leq +75\text{ °C}$ ($-4\text{ °F} \leq T_a \leq +167\text{ °F}$)
CEC (Canada)	Class I/II/III Div 2 T4 Groups ABCDEFG Ex nA IIC T4 Gc Ex tc IIC T130 °C Dc $-20\text{ °C} \leq T_a \leq +75\text{ °C}$ ($-4\text{ °F} \leq T_a \leq +167\text{ °F}$)

Fig. 3: Certifications GTE Analog

TECHNICAL DRAWING

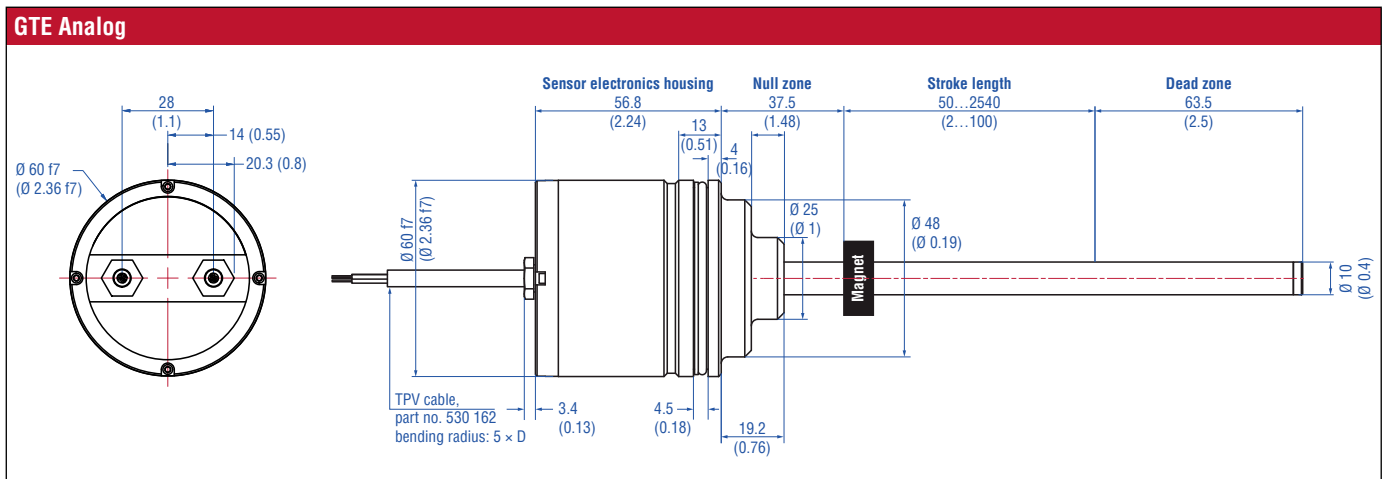

Fig. 4: Temposonics® GTE with ring magnet

CONNECTOR WIRING

BXX		
Signal + power supply		
Cable	Color	Function
	GY	Position
	PK	Signal ground
	YE	Programming (RS-485 +)
	GN	Programming (RS-485 -)
	BN	Supply voltage
	WH	DC Ground (0 V)
	Shield	Only connected on controller side

Fig. 5: Connector wiring

FREQUENTLY ORDERED ACCESSORIES – Additional options available in our [Accessories Guide](#) 551444

Position magnets	Magnet spacer
<p>U-magnet OD33 Part no. 251 416-2</p> <p>Material: PA ferrite GF20 Weight: Approx. 11 g Surface pressure: Max. 40 N/mm² Fastening torque for M4 screws: 1 Nm Operating temperature: -40...+105 °C (-40...+221 °F)</p>	<p>Ring magnet OD33 Part no. 201 542-2</p> <p>Material: PA ferrite GF20 Weight: Approx. 14 g Surface pressure: Max. 40 N/mm² Fastening torque for M4 screws: 1 Nm Operating temperature: -40...+105 °C (-40...+221 °F)</p>
<p>Ring magnet OD25.4 Part no. 400 533</p> <p>Material: PA ferrite Weight: Approx. 10 g Surface pressure: Max. 40 N/mm² Operating temperature: -40...+105 °C (-40...+221 °F)</p>	<p>Magnet spacer Part no. 400 633</p> <p>Material: Aluminum Weight: Approx. 5 g Surface pressure: Max. 20 N/mm² Fastening torque for M4 screws: 1 Nm</p>

Programming tool



Hand programmer for analog output Part no. 253 853

Easy teach-in-setups of stroke length and direction on desired zero / span positions. For sensors with 1 magnet.

ORDER CODE

1	2	3	4	5	6	7	8	9	10	11	12	13	14	15	16
G	T	E						B	0		1				
a			b					c			d	e		f	

optional

a	Sensor model
G T E	Embedded pressure-fit flange Ø 60 mm (2.36 in.)

b	Stroke length
X X X X M	0050...2540 mm
Standard stroke length (mm)	
Ordering steps	
50... 500 mm	5 mm
500... 750 mm	10 mm
750...1000 mm	25 mm
1000...2540 mm	50 mm
X X X X U	002.0...100.0 in.
Standard stroke length (in.)	
Ordering steps	
2... 20 in.	0.2 in.
20... 30 in.	0.4 in.
30... 40 in.	1.0 in.
40...100 in.	2.0 in.
Non-standard stroke lengths are available; must be encoded in 5 mm/0.1 in. increments.	

c	Connection type
B 0 1	1 m/3 ft. TPV cable (part no. 530 162)
B 0 3	3 m/10 ft. TPV cable (part no. 530 162)
B 0 5	5 m/16 ft. TPV cable (part no. 530 162)

d	Operating voltage
1	+24 VDC (-15/+20 %) (T _{amb} max. +75 °C (+167 °F))

e	Output
A 0	4...20 mA
A 1	20...4 mA
A 2	0...20 mA
A 3	20...0 mA
V 0	0...+10 VDC
V 1	+10...0 VDC
V 2	-10...+10 VDC
V 3	+10...-10 VDC

Optional:

f	Agency approval
E X	Approved version

DELIVERY



- Sensor
- O-ring
- Back-up ring

Accessories have to be ordered separately.

Manuals, Certificates, Software & 3D Models available at:
www.temposonics.com

UNITED STATES
Temposonics, LLC
 Americas & APAC Region
 3001 Sheldon Drive
 Cary, N.C. 27513
 Phone: +1 919 677-0100
 E-mail: info.us@temposonics.com

GERMANY
Temposonics
GmbH & Co. KG
 EMEA Region & India
 Auf dem Schüffel 9
 58513 Lüdenscheid
 Phone: +49 2351 9587-0
 E-mail: info.de@temposonics.com

ITALY
 Branch Office
 Phone: +39 030 988 3819
 E-mail: info.it@temposonics.com

FRANCE
 Branch Office
 Phone: +33 6 14 060 728
 E-mail: info.fr@temposonics.com

UK
 Branch Office
 Phone: +44 79 44 15 03 00
 E-mail: info.uk@temposonics.com

SCANDINAVIA
 Branch Office
 Phone: + 46 70 29 91 281
 E-mail: info.sca@temposonics.com

CHINA
 Branch Office
 Phone: +86 21 2415 1000 / 2415 1001
 E-mail: info.cn@temposonics.com

JAPAN
 Branch Office
 Phone: +81 3 6416 1063
 E-mail: info.jp@temposonics.com

Document Part Number:
 551386 Revision E (EN) 12/2020



temposonics.com